



트윈 롱바디 160W 제품사양서



- 본 제품은 기존 400W HQI 대체용으로서
기존 제품 60%~70%의 광속 증가와 최적의 배광
- 완전방수, 방진, 방습(IP67특허인증)
- 전기료 50%~60% 절감으로 경제적 효과(HQI 대비)
- 총광속 16,400lm / 조도 6,200lux(1m) 의 탁월한 효과
- 친환경 LED

LED LIGHTING FOR PROFESSIONAL & SPECIAL PURPOSE

CONTENTS

We are committed to provide high performance,high quality,high durability product as a reasonable price that lighting experts wanted,We aim for world best in outdoorlighting and specific object lighting e-GM Tech,Co,Ltd

1.제품개요(구성도,사양)

2.악세사리

3.제품설치방법

4.포장

5.인증서

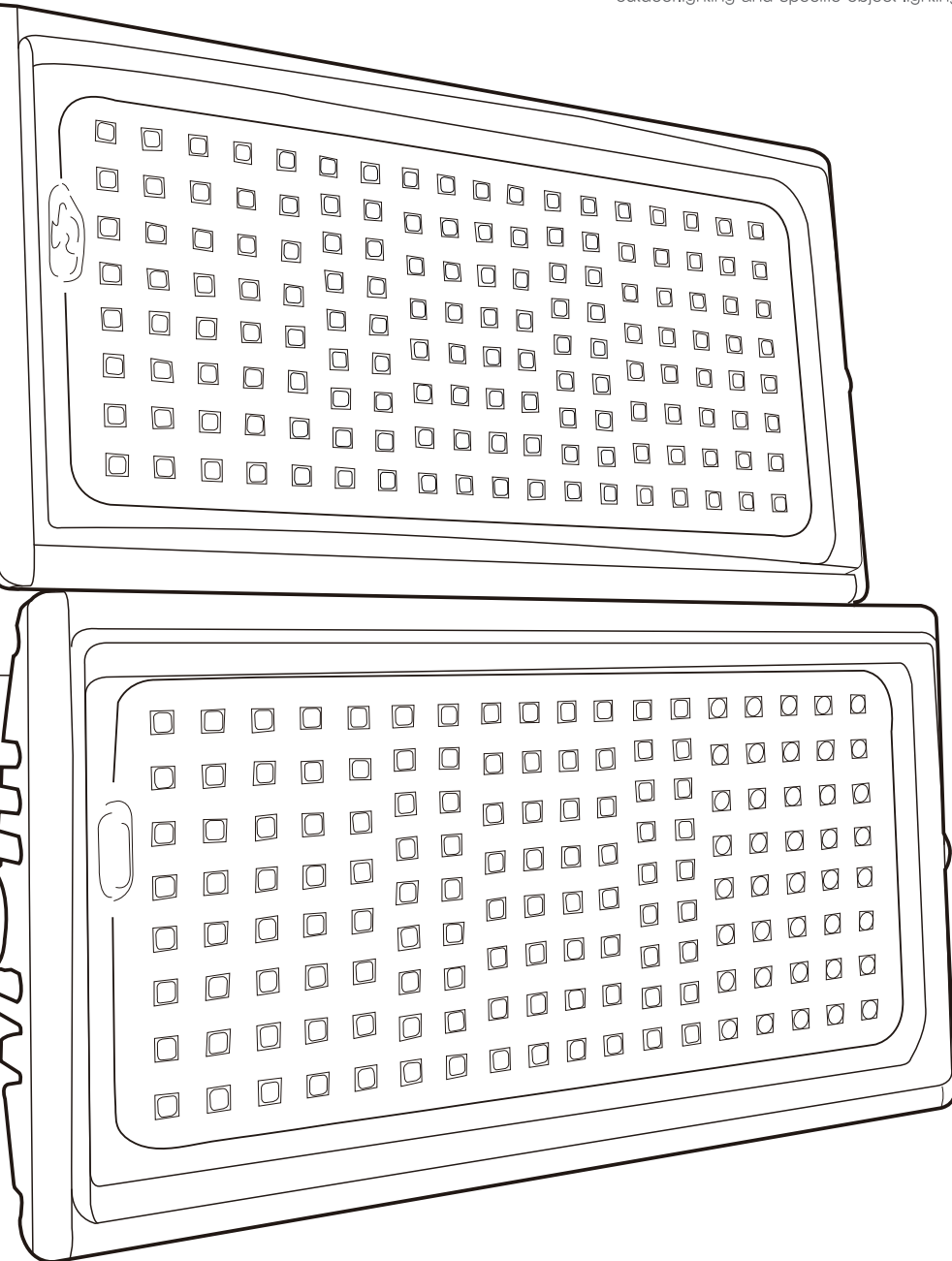

A.제품개요(구성도,사양)

Structure of product

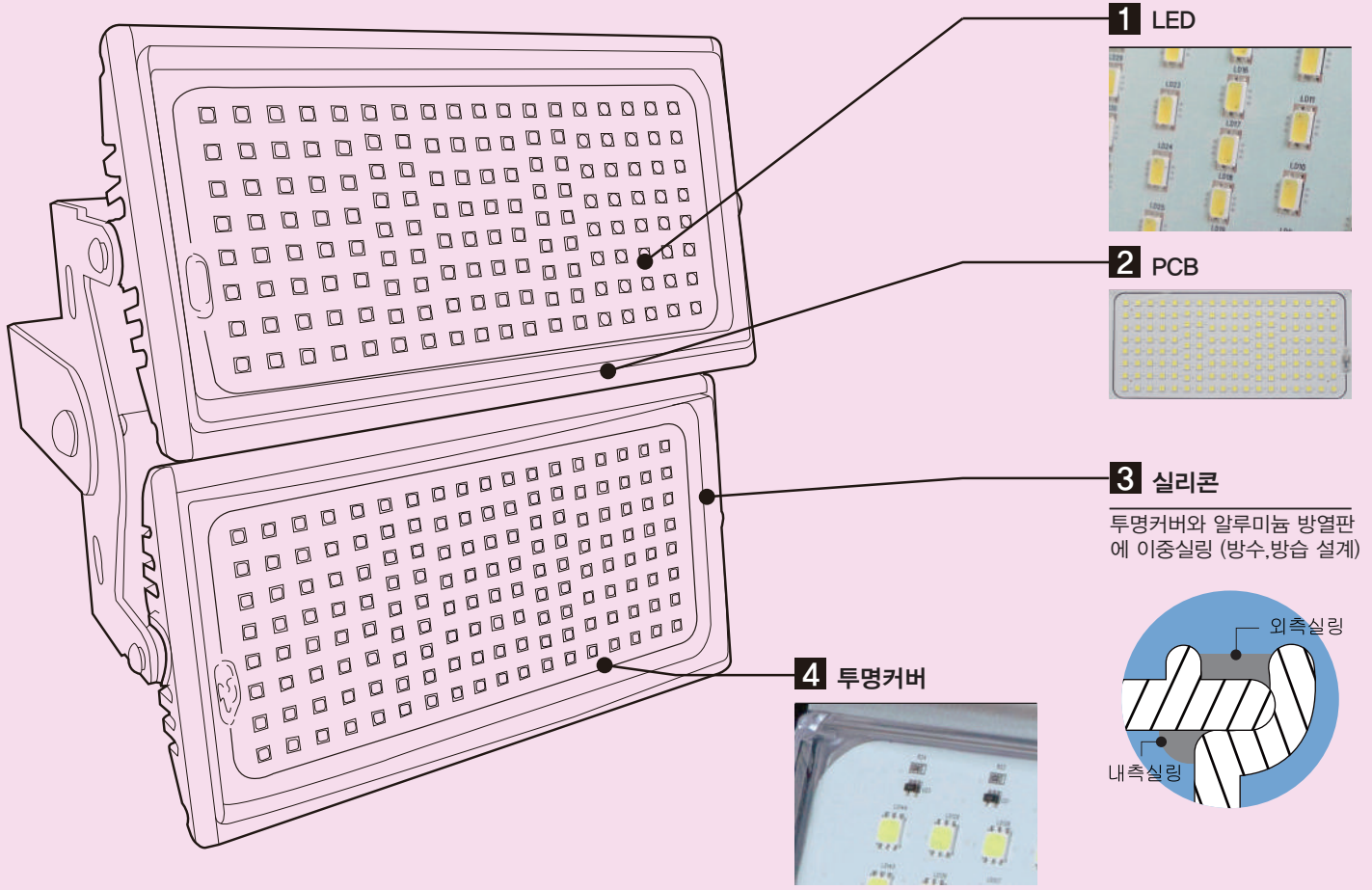

광학적 사양(Optical Specification) # ALNP001 적용

총광속	조도(1M)	조사각	연색성	색온도
16,400(lm)	6,200(lux)	120°	75이상	6,000K

↓ 다리 및 교량 적용 가능 사례



조도 & 배광 그래프

광속 16,400(lm) 조도6,200(lux/1m)

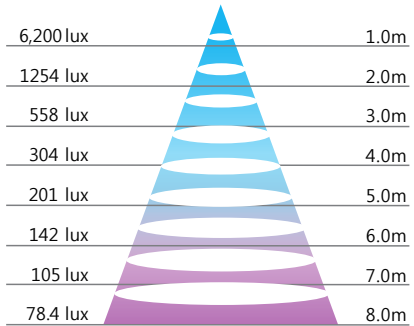

조사각 120

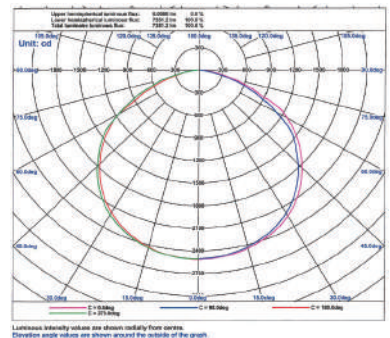

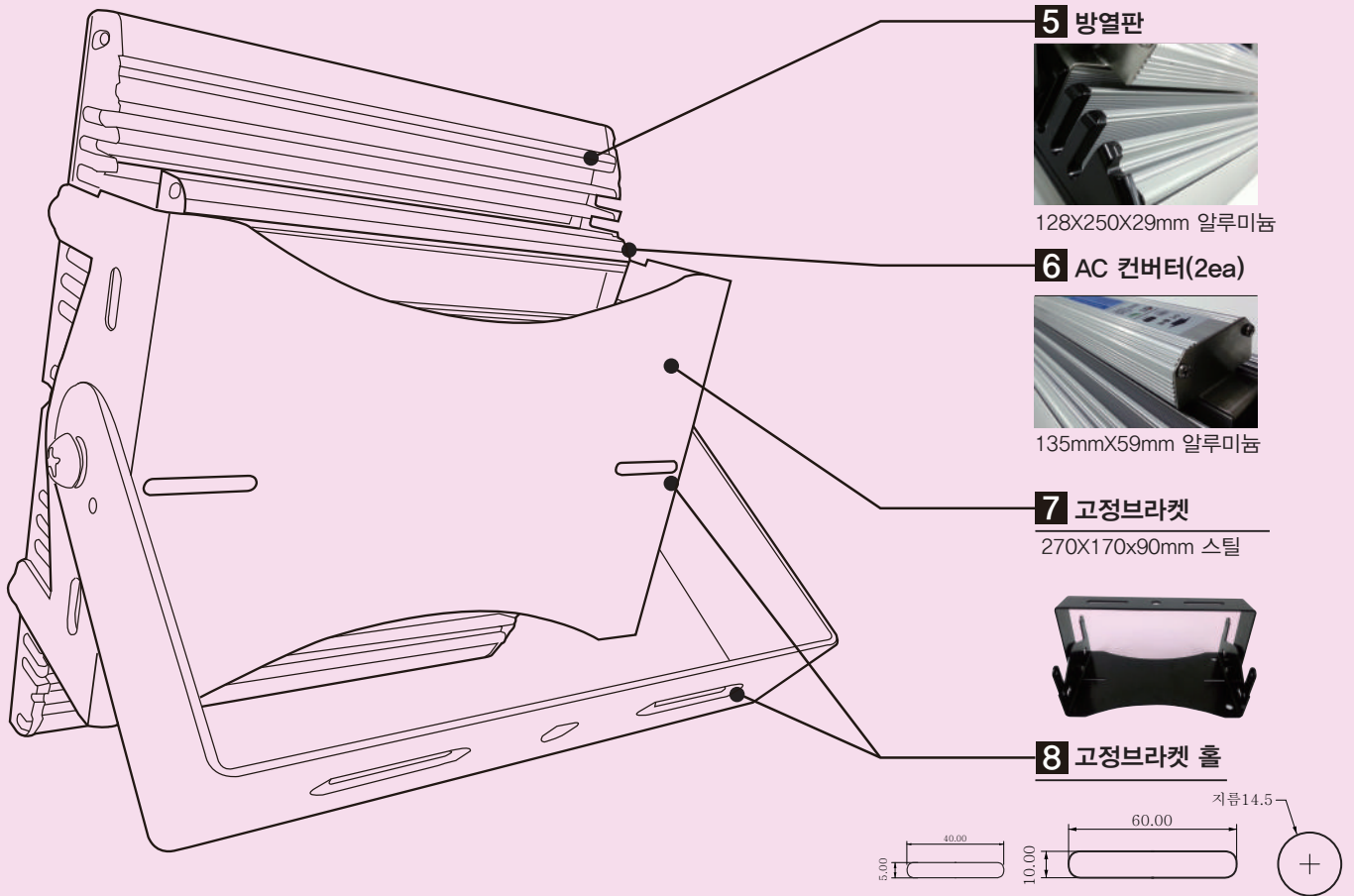

B.제품개요(구성도,사양)

Structure of product



전기적 사양(Electronic Specification)

 소비전력	 입력전원	 역률
160W	AC220V,50/60HZ (190V~AC290V)	0.90이상

기술적 사양(Technical Specification)

 방수등급	 무게	 작동온도
IP67	5Kg	-50~55°C

Dimension

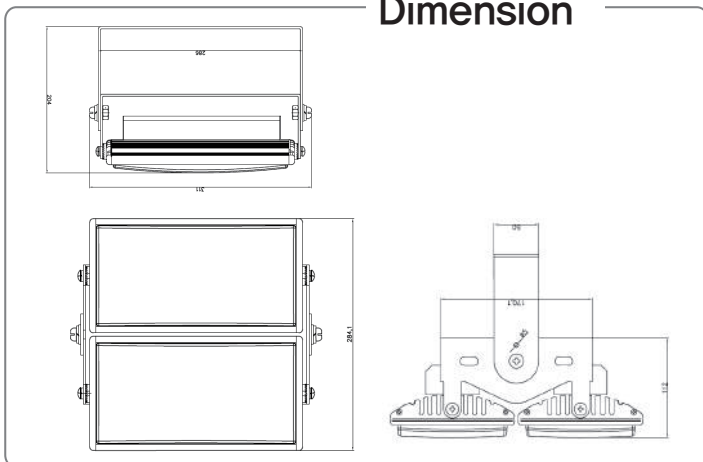

적용 가능



1. 직부설치

① C자브라켓 (기본 구성품)

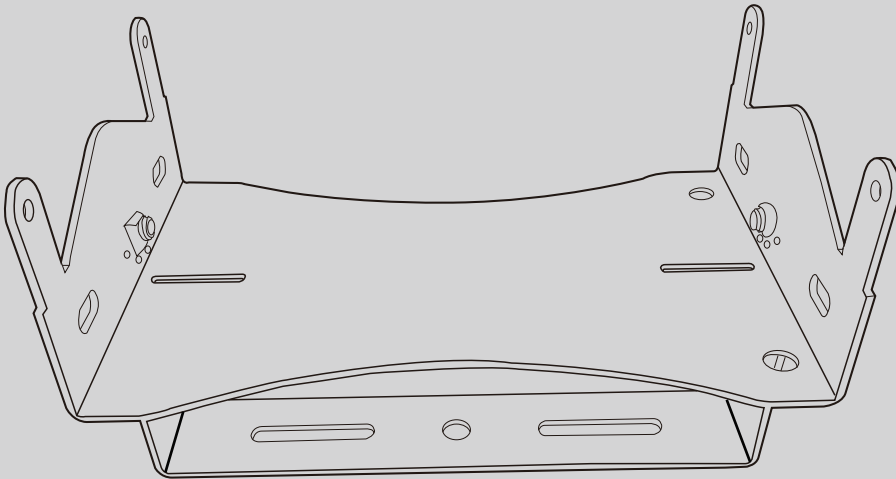

② 관절고정세트(기본 구성품)

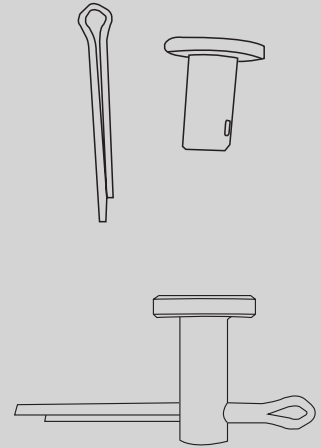

2. 파이프 연결 설치

① 트윈 가로등 브라켓 (기본 구성품)

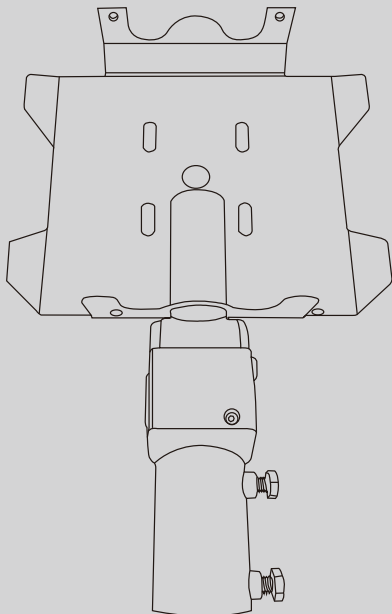

② 육각렌치(기본 구성품)

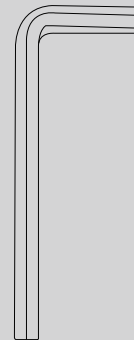

제품 설치 방법

Mounting arrangement

1. 직부설치

구성 A. ㄷ자 브라켓 + 각도 고정 세트(너트, 핀)

A. ㄷ자 브라켓 + 각도 고정 세트(너트, 핀)

① 제품을 ㄷ자 홈에 나사로 고정

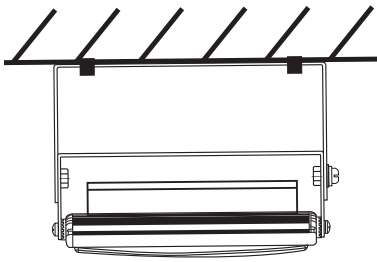

② 관절 고정세트중 핀을 이용하여 브라켓 각도 조절 후 핀으로 고정

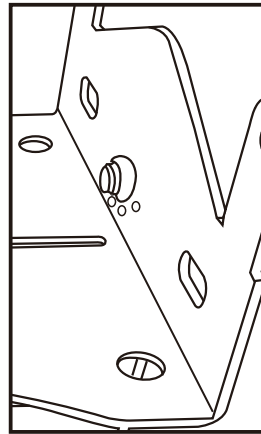

③ 투광등 각각 조절 가능

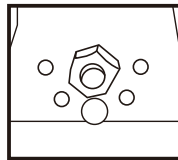
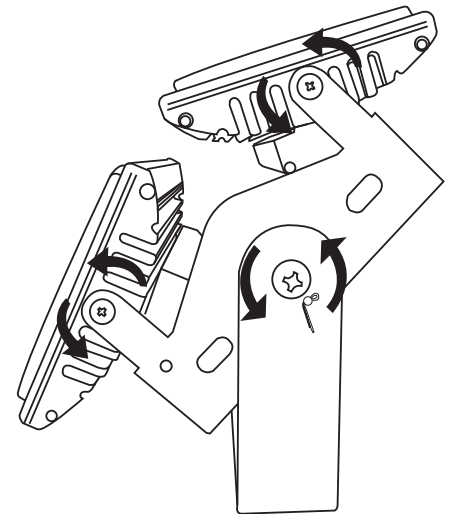

(0도 45도 90도)

2. 폴대 설치

A. 가로등 브라켓 + 육각렌치(각도 조절용)

A. 가로등 브라켓 + 육각렌치(각도 조절용)

① 조임나사를 이용하여 가로등과 결합

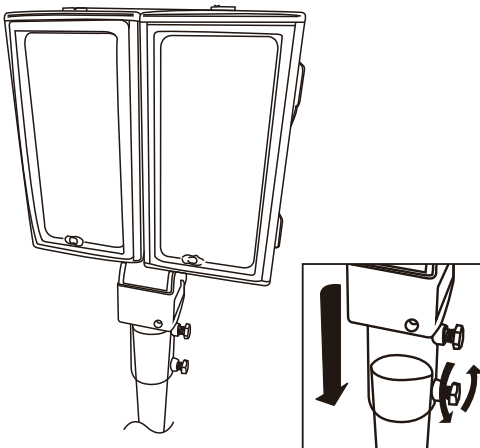

② 육각렌치로 각도 조절 (전후 30도)

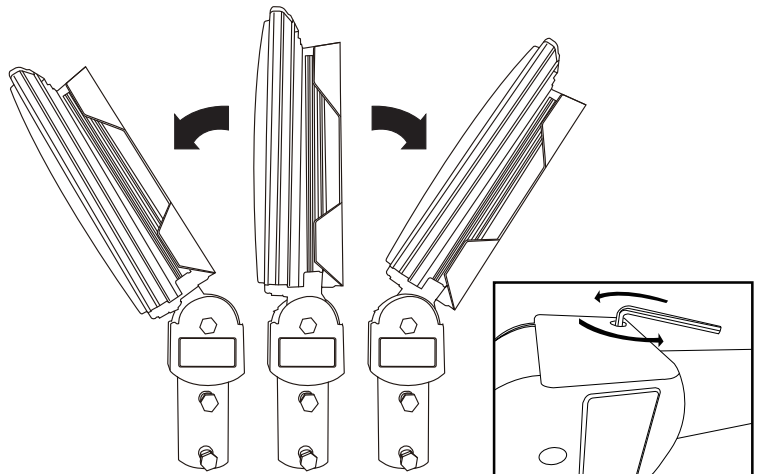

1. 포장(内)

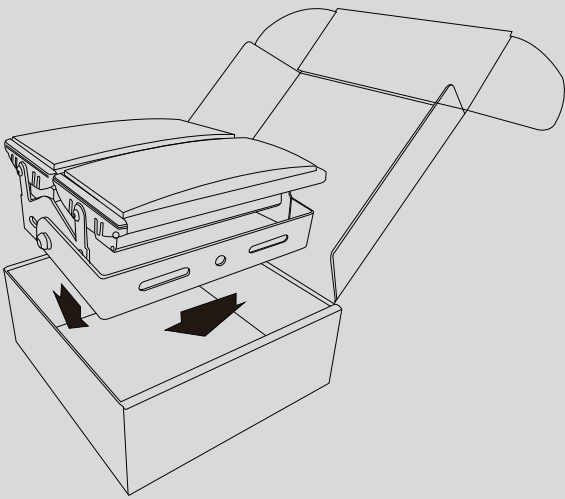

2. 내포장형태

- 상자규격: 325(l)X305(w)X125(h)

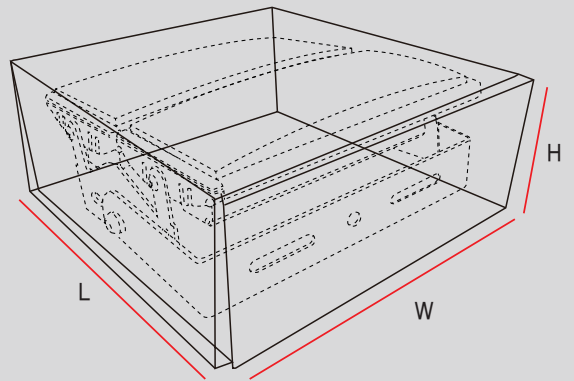

3. 외포장형태

- 상자규격: 630(l)X135(w)X315(h)
- 박스재질: 골판지(DW)

5개입X1단

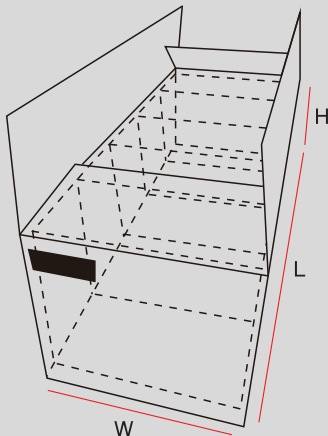

4. 파렛트 적재 형태

- 파렛트규격: 1100(l)X1100(w)X1700(h)
- 파렛트재질: 플라스틱

4개입X5단

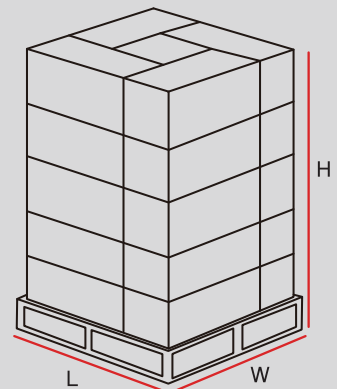
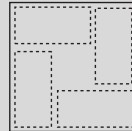

접수번호(Order No.) : EKC2014-2596



전기용품 안전 인증서
Electrical Appliances Safety Certificate

안전인증번호 : JL11032-14002
(Certificate No.)

제조업자명 : 주식회사 이지엠테크
(Manufacturer)

대표자명 : 김승훈
(President)

제조공장의소재지 : 경상북도 구미시 1공단로2길 13 (공단동)
(Factory Address)

제품명 : 조명기구용컨버터(LED램프용)
(Product) (Converter for luminaires for LED Converter)

기본모델명 : EGM70-NEO
(Basic Model)

정격 : 220 V~, 60 Hz, 70 W
(Rating)

파생모델명 : EGM100-NEO, EGM60-NEO, EGM80-NEO, EGM90-NEO
(Series Model)

적용기준 : KC61347-1(2014-09), KC61347-2-13(2014-09), KC62384(2014-09)
(Standard)

「전기용품안전관리법 시행규칙」 제6조 제2항의 규정에 따라 위의 전기용품에 대하여 안전인증서를 발급합니다.

We Issue Electrical Appliances Safety Certification as above product by Article 6 Section 2 of the Electrical Appliances Safety Control Enforcement Regulation.

2014년 11월 13일
year month day



※ 이 인증서는 「전기용품안전관리법」에 따른 전기용품안전성 확인에 한정된 것이며 그 밖의 다른 법률이 적용되는 제품의 경우에는 해당법률에 따라 추가로 인증·허가 등을 받아야 합니다.

- 1. 안전관리부품 및 재질목록(List of Critical components)
 - 2. 기본모델·파생모델의 내용(General Descriptions of Certified Products)
- 첨부서류 (Annex)

